

Solid State Relay G3NA

New Models with 75-A and 90-A Output Currents Join the Previous Models with 5- to 50-A Output Currents.

- AC Output Relays with 75-A and 90-A output currents have been added to the G3NA Series. The standard versions of these models provide certification for international standards (-UTU).
- All models feature the same compact dimensions to provide a uniform mounting pitch.
- Built-in varistor effectively absorbs external surges.
- Operation indicator enables monitoring operation.
- Protective cover for greater safety.
- Standard models certified by UL and CSA and -UTU models by VDE (TÜV).

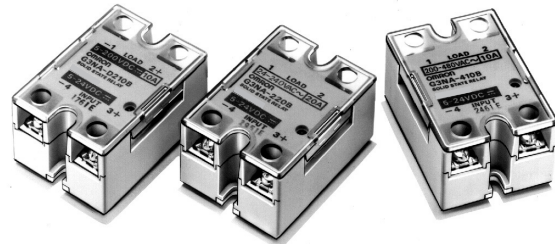

Ordering Information

To Order: Select the part number and add the desired rated input voltage, (e.g., G3NA-240B-100 to 120 VAC)

Isolation	Zero cross function	Indicator	Rated output load (applicable output load)	Rated input voltage	Model
Phototriac	Yes	Yes	5 A at 24 to 240 VAC* (19 to 264 VAC)	5 to 24 VDC	G3NA-205B
Photocoupler				100 to 120 VAC	
	200 to 240 VAC				
Phototriac			10 A at 24 to 240 VAC* (19 to 264 VAC)	5 to 24 VDC	G3NA-210B
Photocoupler				100 to 120 VAC	
				200 to 240 VAC	
Phototriac			20 A at 24 to 240 VAC* (19 to 264 VAC)	5 to 24 VDC	G3NA-220B
Photocoupler				100 to 120 VAC	
				200 to 240 VAC	
			25 A at 24 to 240 VAC* (19 to 264 VAC)	5 to 24 VDC	G3NA-225B
				100 to 120 VAC	
				200 to 240 VAC	
			25 A at 200 to 480 VAC* (180 to 528 VAC)	5 to 24 VDC	G3NA-425B
				100 to 240 VAC	

(Table continued on next page.)

Isolation	Zero cross function	Indicator	Rated output load (applicable output load)	Rated input voltage	Model				
Phototriac	Yes	Yes	40 A at 24 to 240 VAC* (19 to 264 VAC)	5 to 24 VDC	G3NA-240B				
Photocoupler				100 to 120 VAC					
				200 to 240 VAC					
Phototriac			—	Yes	75 A at 24 to 240 VAC* (19 to 264 VAC)	5 to 24 VDC	G3NA-275B-UTU		
Photocoupler						100 to 240 VAC			
Phototriac					90 A at 24 to 240 VAC* (19 to 264 VAC)	5 to 24 VDC	G3NA-290B-UTU		
Photocoupler						100 to 240 VAC			
					10 A at 5 to 200 VDC* (4 to 220 VDC)	5 to 24 VDC	G3NA-D210B		
						100 to 240 VAC			
					Yes	Yes	10 A at 200 to 480 VAC* (180 to 528 VAC)	5 to 24 VDC	G3NA-410B
								100 to 240 VAC	
							20 A at 200 to 480 VAC* (180 to 528 VAC)	5 to 24 VDC	G3NA-420B
	100 to 240 VAC								
	40 A at 200 to 480 VAC* (180 to 528 VAC)	5 to 24 VDC					G3NA-440B		
		100 to 240 VAC							
	50 A at 200 to 480 VAC (180 to 528 VAC)	5 to 24 VDC	G3NA-450B						
	75 A at 200 to 480 VAC (180 to 528 VAC)	5 to 24 VDC	G3NA-475B-UTU						
		100 to 240 VAC							
	90 A at 200 to 480 VAC (180 to 528 VAC)	5 to 24 VDC	G3NA-490B-UTU						
		100 to 240 VAC							

*Loss time increases under 75 VAC.

Note: 1. When ordering a TÜV-approved model, add “-UTU” to the model number as shown below:

Example: G3NA-210B-UTU.

2. G3NA-4 are not CE marked.
3. G3NA-2 with “-UTU” are CE marked.

■ Accessories

Heat Sinks

Types	Applicable solid-state relays	Model
Standard mount	G3NA-205B, G3NA-210B, G3NA-D210B, G3NA-220B, G3NA-410B, G3NA-420B	Y92B-A100
	G3NA-225B, G3NA-240B, G3NA-425B, G3NA-440B	Y92B-A150N
	G3NA-440B	Y92B-A250
Track mount	G3NA-205B, G3NA-210B, G3NA-D210B, G3NA-410B	Y92B-N50
	G3NA-220B, G3NA-420B	Y92B-N100
	G3NA-225B, G3NA-240B, G3NA-425B, G3NA-440B	Y92B-N150
	G3NA-450B	Y92B-P250
	G3NA-275B-UTU, G3NA-290B-UTU, G3NA-475B-UTU, G3NA-490B-UTU	Y92B-P250NF

Mounting Track and Accessories

Description	Model
Mounting bracket for G3NA-240B. Changes pitch to 56 mm (2.21 in.) from 47.5 mm (1.73 in.), the same pitch as G3N-240B.	R99-11
DIN Rail Track, 50 cm (1.64 feet) length; use with Y92B-N□□□ heat sinks	PFP-50N
DIN Rail Track, 1 m (3.28 feet) length; use with Y92B-N□□□ heat sinks	PFP-100N
Spacer	PFP-S
End cap	PFP-M
One-touch mounting plates	R99-12 FOR G3NA

Specifications

Input Ratings

(Ambient temperature: 25°C [77°F])

Type	Rated voltage	Operating voltage range	Impedance (See note 1)	Voltage level	
				Must operate voltage	Must release voltage
G3NA-2□□B	5 to 24 VDC	4 to 32 VDC	7 mA max. (see note 2)	4 VDC max.	1 VDC min.
	100 to 120 VAC	75 to 132 VAC	36 kΩ ±20%	75 VAC max. (see note 3)	20 VAC min. (see note 3)
	200 to 240 VAC	150 to 264 VAC	72 kΩ ±20%	150 VAC max. (see note 3)	40 VAC min. (see note 3)
G3NA-4□□B	5 to 24 VDC	4 to 32 VDC	5 mA max. (see note 2)	4 VDC max.	1 VDC min.
G3NA-D210B	100 to 240 VAC	75 to 264 VAC	72 kΩ ±20%	75 VAC max.	20 VAC min.
G3NA-275B-UTU	5 to 24 VDC	4 to 32 VDC	15 mA max. (see note 2)	4 VDC max.	1 VDC min.
G3NA-290B-UTU	100 to 240 VAC	75 to 264 VAC	72 kΩ ±20%	75 VAC max.	20 VAC min.
G3NA-475B-UTU	5 to 24 VDC	4 to 32 VDC	15 mA max. (see note 2)	4 VDC max.	1 VDC min.
G3NA-490B-UTU	100 to 240 VAC	75 to 264 VAC	72 kΩ ±20%	75 VAC max.	20 VAC min.

Note: 1. The input impedance is measured at the maximum value of the rated supply voltage (for example, with the model rated at 100 to 120 VAC, the input impedance is measured at 120 VAC).

2. With constant current input circuit system, the impedance for the G3NA-2□□B-UTU is 15mA max.

3. Refer to the “Characteristic Data” for further details.

Output Ratings

Type	Applicable load				
	Rated load voltage	Load voltage range	Load current		Surge current
			With heat sink*	Without heat sink	
G3NA-205B	24 to 240 VAC	19 to 264 VAC	0.1 to 5 A (at 40°C)	0.1 to 3 A (at 40°C)	60 A (60 Hz, 1 cycle)
G3NA-210B	24 to 240 VAC	19 to 264 VAC	0.1 to 10 A (at 40°C)	0.1 to 4 A (at 40°C)	150 A (60 Hz, 1 cycle)
G3NA-410B	200 to 480 VAC	180 to 528 VAC	0.2 to 10 A (at 40°C)	0.2 to 4 A (at 40°C)	
G3NA-220B	24 to 240 VAC	19 to 264 VAC	0.1 to 20 A (at 40°C)	0.1 to 4 A (at 40°C)	220 A (60 Hz, 1 cycle)
G3NA-420B	200 to 480 VAC	180 to 528 VAC	0.2 to 20 A (at 40°C)	0.2 to 4 A (at 40°C)	
G3NA-240B	24 to 240 VAC	19 to 264 VAC	0.1 to 40 A (at 40°C)	0.1 to 6 A (at 40°C)	440 A (60 Hz, 1 cycle)
G3NA-440B	200 to 480 VAC	180 to 528 VAC	0.2 to 40 A (at 40°C)	0.2 to 6 A (at 40°C)	
G3NA-450B	200 to 480 VAC	180 to 528 VAC	0.2 to 50 A (at 40°C)	0.2 to 6 A (at 40°C)	
G3NA-D210B	5 to 200 VDC	4 to 220 VDC	0.1 to 10 A (at 40°C)	0.1 to 4 A (at 40°C)	20 A (10 ms)
G3NA-275B-UTU	24 to 240 VAC	19 to 264 VAC	1 to 75 A (at 40°C)	1 to 7 A (at 40°C)	800 A (60 Hz, 1 cycle)
G3NA-475B-UTU	200 to 480 VAC	180 to 528 VAC	1 to 75 A (at 40°C)	1 to 7 A (at 40°C)	800 A (60 Hz, 1 cycle)
G3NA-290B-UTU	24 to 240 VAC	19 to 264 VAC	1 to 90 A (at 40°C)	1 to 7 A (at 40°C)	1,000 A (60 Hz, 1 cycle)
G3NA-490B-UTU	200 to 480 VAC	180 to 528 VAC	1 to 90 A (at 40°C)	1 to 7 A (at 40°C)	1,000 A (60 Hz, 1 cycle)

*When the appropriate size OMRON heat sink is used.

■ Characteristics

Type		G3NA-205B, -210B, -220B, -225B	G3NA-240B	G3NA-410B, -420B, -425B, -440B, -450B	G3NA- D210B	G3NA- 275B- UTU	G3NA- 290B- UTU	G3NA- 475B- UTU	G3NA- 490B- UTU
Operate time	DC input	1/2 of load power source cycle + 1 ms max.			1 ms max.	1/2 of load power source cycle + 1 ms max.			
	AC input	1 1/2 of load power source cycle + 1 ms max.			30 ms max.	3/2 of load power source cycle + 1 ms max.			
Release time	DC input	1/2 of load power source cycle + 1 ms max.			5 ms max.	1/2 of load power source cycle + 1 ms max.			
	AC input	1 1/2 of load power source cycle + 1 ms max.			30 ms max.	3/2 of load power source cycle + 1 ms max.			
Output ON voltage drop		1.6 V (RMS) max.	1.6 V (RMS) max.	1.8 V (RMS max.)	1.5 V max.	1.6 V (RMS) max.		1.8 V (RMS) max.	
Leakage current		5 mA max. at 100 VAC		10 mA max. at 200 VAC	5 mA max. at 200 VDC	5 mA max. at 100 VAC		10 mA max. at 200 VDC	
		10 mA max. at 200 VAC		20 mA max. at 400 VAC		10 mA max. at 200 VAC		20 mA max. at 400 VAC	
Insulation resistance		100 MΩ min at 500 VDC							
Dielectric strength		2,500 VAC, 50/60 Hz for 1 minute				4,000 VAC, 50/60 Hz for 1 min.			
Vibration	Malfunction	10 to 55 Hz, 1.5 mm double amplitude							
Shock	Malfunction	1,000 m/s ² (approx. 100G)							
Ambient temperature	Operating	-30° to 80°C (-22° to 176°F) with no icing							
	Storage	-30° to 100°C (-22° to 212°F) with no icing							
Humidity		45% to 85% RH							
Weight		Approx. 60 g (2.1 oz.)	Approx. 70 g (2.5 oz.)	Approx. 80 g (2.8 oz.)	Approx. 70 g (2.5 oz.)	Approx. 120 g			

Note: Data shown are of initial value.

Engineering Data

Load Current vs. Ambient Temperature

G3NA-205B

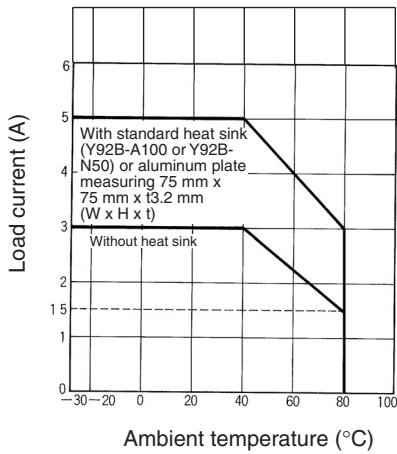

G3NA-210B/410B

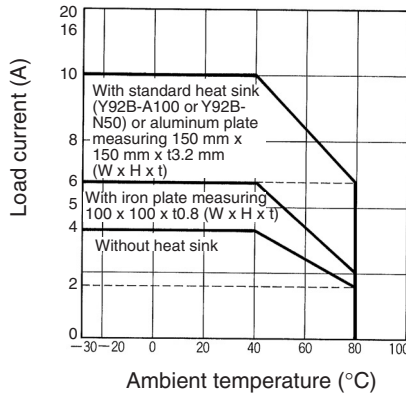

G3NA-220B/420B

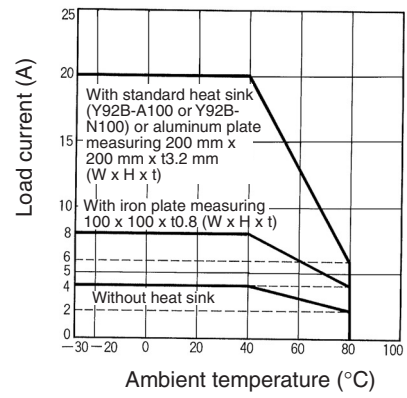

G3NA-240B

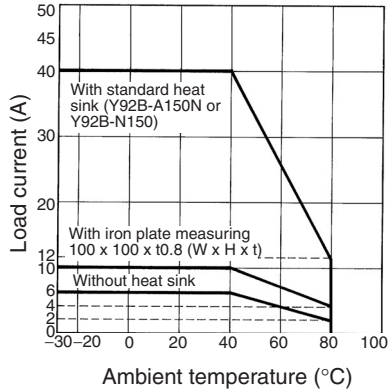

G3NA-440B

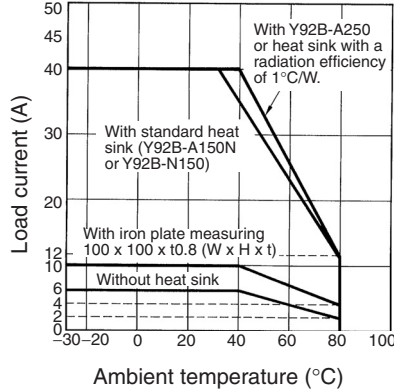

G3NA-450B

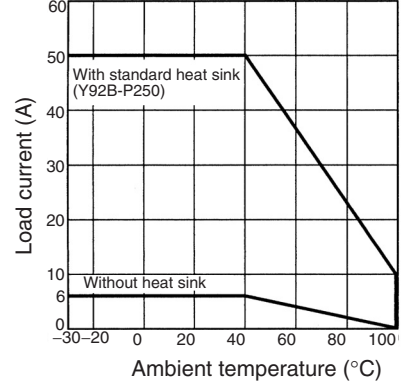

G3NA-275B-UTU

G3NA-475B-UTU

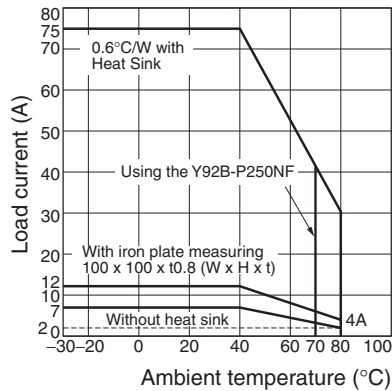

G3NA-290B-UTU

G3NA-490B-UTU

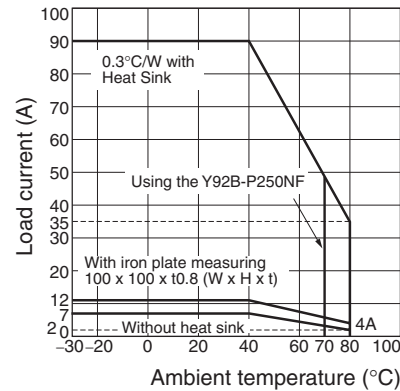

G3NA-D210B

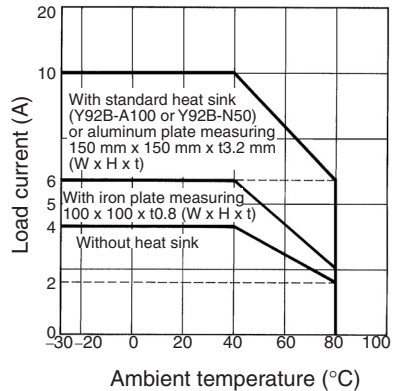

Note: The ambient operating temperature of the Y92B-P250NF is – 30 to 70°C. Be sure the operating temperature is within this range.

One Cycle Surge Current

The values shown by the solid line are for non-repetitive inrush currents. Keep the inrush current below the values shown by the dotted line if it occurs repetitively.

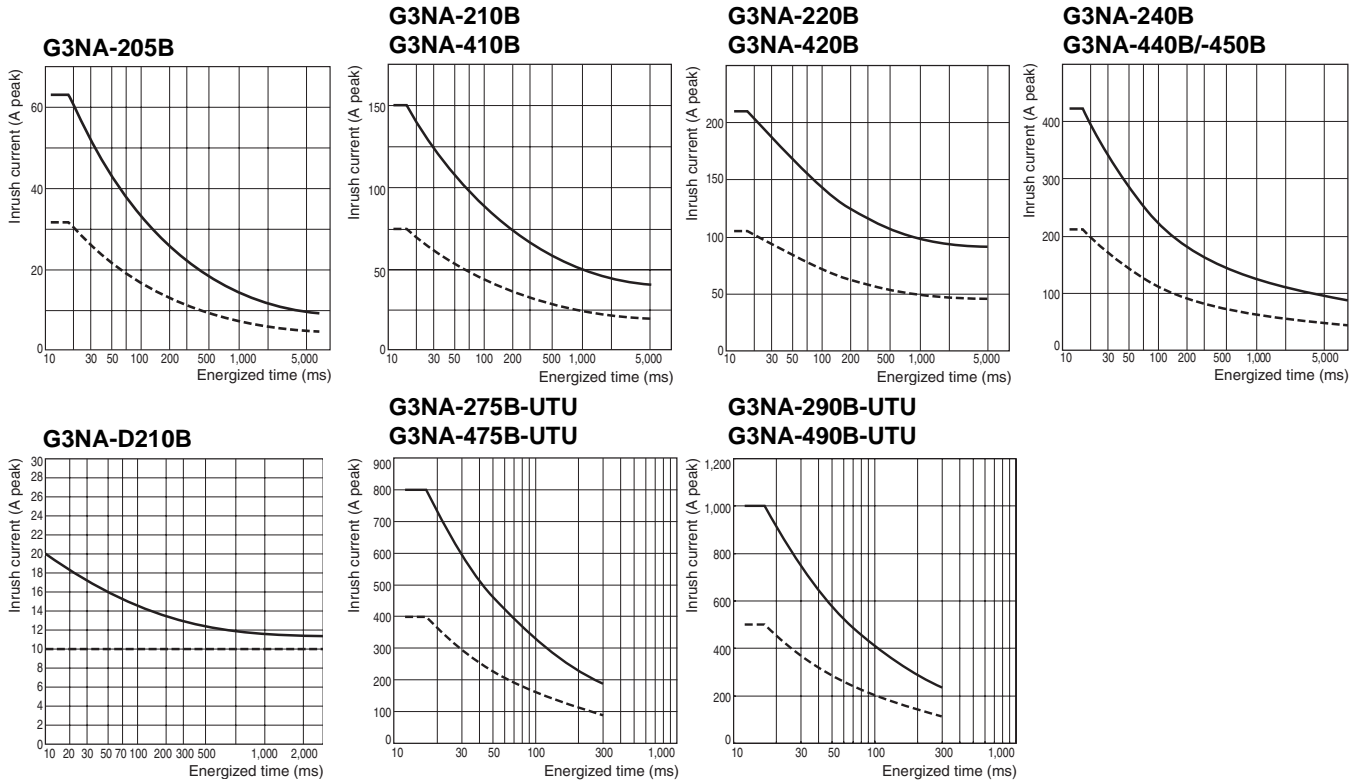

Temperature Characteristics (for Must Operate Voltage and Must Release Voltage)

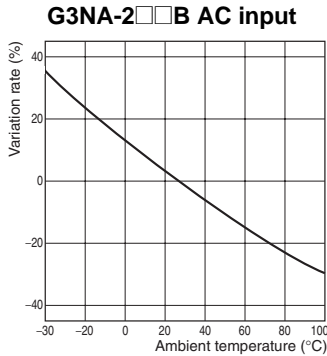

Heat Sink Area vs. Load Current

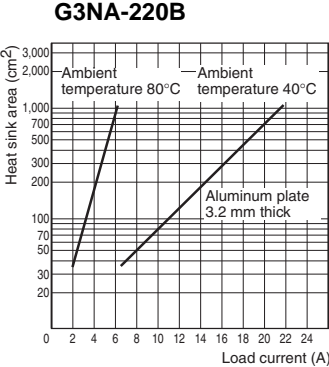

Note: The heat sink area refers to the combined area of the sides of the heat sink that radiate heat. For example, when a current of 18 A is allowed to flow through the SSR at 40°C, the graph shows that the heat sink area is about 450 cm². Therefore, if the heat sink is square, one side of the heat sink must be 15 cm ($\sqrt{450 \text{ (cm}^2\text{)}/2}$) or longer.

Thermal Resistance Rth (Back of Junction SSR) (Examples)

Model	Rth (°C/W)
G3NA-205B	3.22
G3NA-210B	2.62
G3NA-220B	1.99
G3NA-240B	0.45
G3NA-275B-UTU G3NA-475B-UTU G3NA-290B-UTU G3NA-490B-UTU	0.45
G3NA-D210B	2.62

Thermal Resistance Rth of Heat Sinks (Examples)

Model	Rth (°C/W)
Y92B-N50	2.8
Y92B-N100	1.63
Y92B-N150	1.38
Y92B-A100	1.63
Y92B-A150N	1.37
Y92B-A250	1.00
Y92B-P250NF	0.46

Note: When using a commercially available heat sink, use one with a thermal resistance equal to or less than the OMRON Heat Sink.

Dimensions

Relays

Note: All units are in millimeters unless otherwise indicated.

G3NA-205B, G3NA-210B, G3NA-220B, G3NA-410B, G3NA-420B

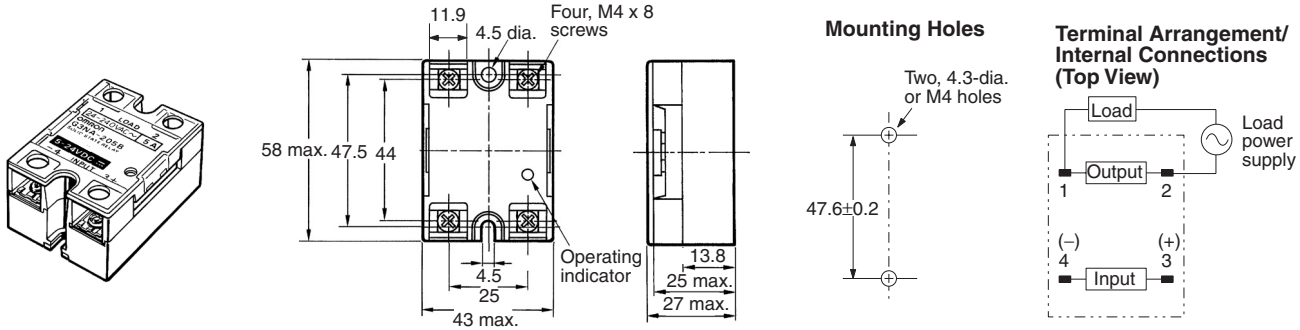

G3NA-240B, G3NA-440B

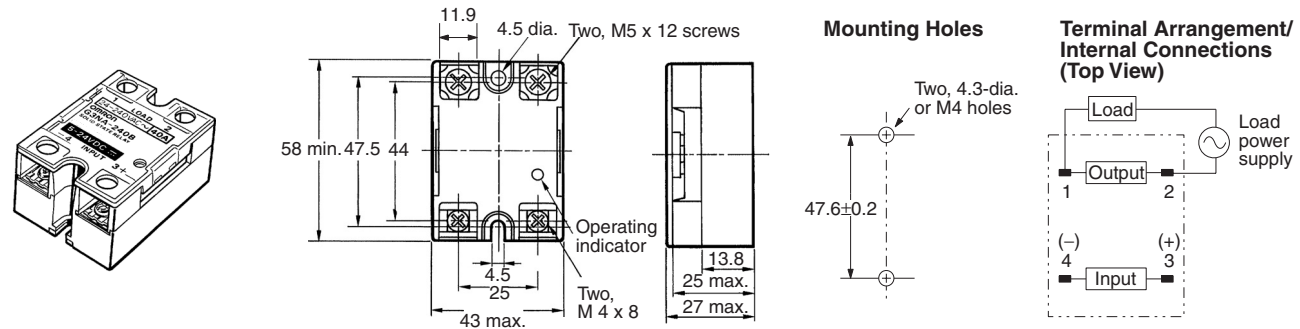

G3NA-D210B

Note: The load can be connected to either the positive or negative side.

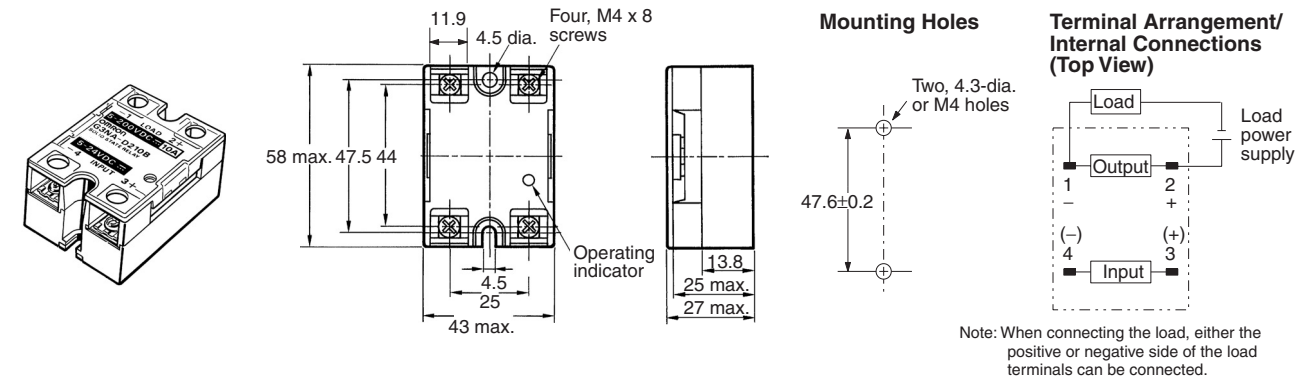

G3NA-275B-UTU, G3NA-475B-UTU, G3NA-290B-UTU, G3NA-490B-UTU

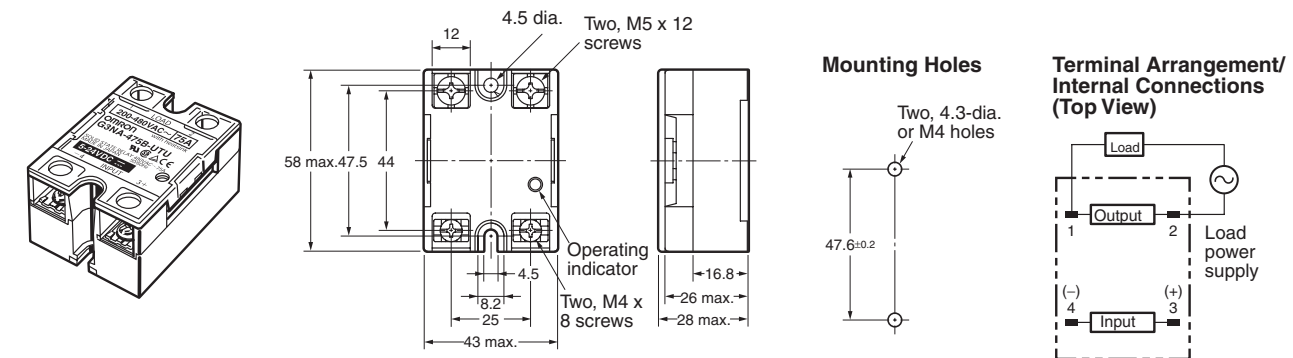

■ Options (Order Separately)

One-touch Mounting Plate

The One-touch Mounting Plate is used to mount the GN3A to a DIN Track.

R99-12 FOR G3NA (for the G3NA and G3NE)

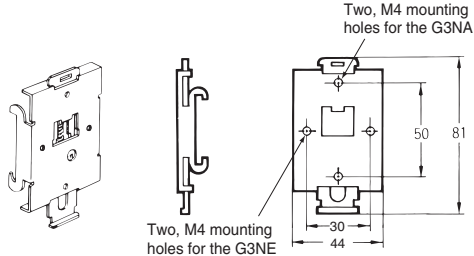

To mount the Relay to DIN Track, first mount it to the One-touch Mounting Plate and then attach it to the DIN Track as shown in the diagram.

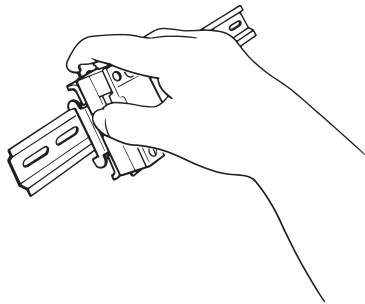

To remove the Relay from the DIN Track, pull down on the tab with a screwdriver in the direction of the arrow.

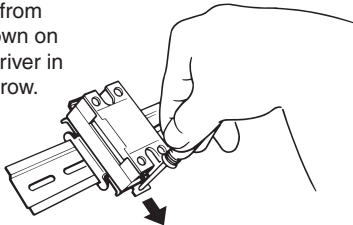

- When a Relay is mounted to DIN Track, use it within the rating for a Relay without a heat sink.
- Use the following DIN Tracks: PFP-100N or PFP-100N2.

Mounting Bracket

R99-11 (for the G3NA-240B, G3NA-440B)

Use Mounting Bracket R99-11 so that the G3NA-240B/440B can be mounted with the same pitch as that of the G3N-240B.

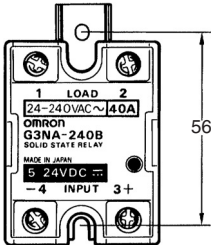
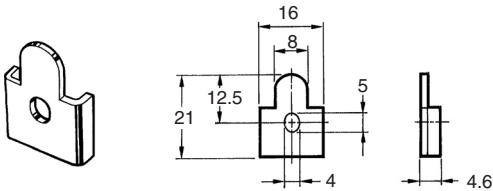

Heat Sinks

Y92B-N50 Heat Sink (for the G3NA-205B, G3NA-210B, G3NA-D210B, G3NA-410B, G3NE-210T(L))

For surface mounting, a 30% derating of the load current is required (from the Load Current vs. Ambient Temperature graphs).

The orientation indicated by the external dimensions is not the correct mounting orientation. When opening mounting holes, refer to the mounting hole dimensions.

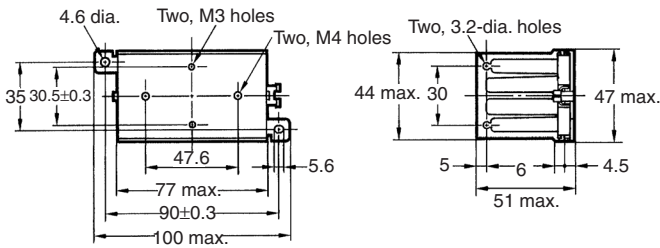
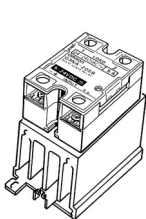

Mounting Holes

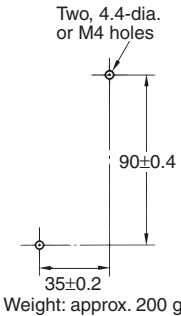

Y92B-N100 Heat Sink (for the G3NA-220B, G3NA-420B, G3NE-220T(L))

For surface mounting, a 30% derating of the load current is required (from the *Load Current vs. Ambient Temperature* graphs). The orientation indicated by the external dimensions is not the correct mounting orientation. When opening mounting holes, refer to the mounting hole dimensions.

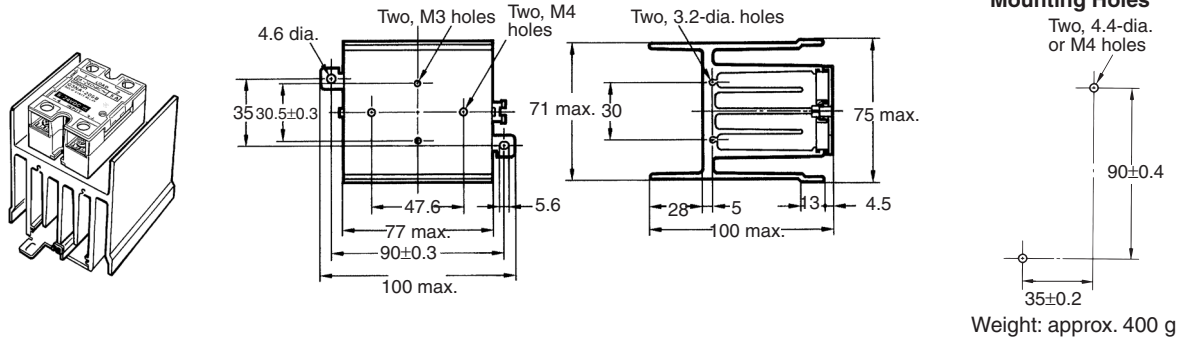

Y92B-N150 Heat Sink (for the G3NA-240B, G3NA-440B)

For surface mounting, a 30% derating of the load current is required (from the *Load Current vs. Ambient Temperature* graphs). The orientation indicated by the external dimensions is not the correct mounting orientation. When opening mounting holes, refer to the mounting hole dimensions.

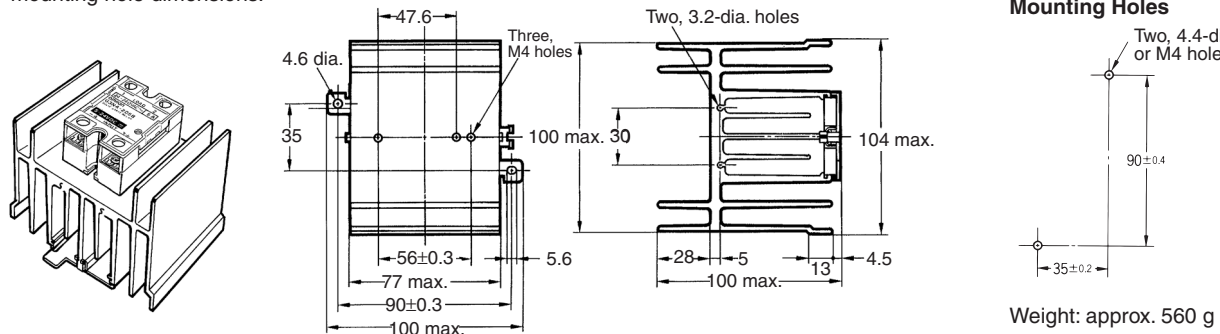

Y92B-P250NF Heat Sink (for the G3NA-275B-UTU, G3NA-475B-UTU, G3NA-290B-UTU, G3NA-490B-UTU)

(The Y92B-P250NF is scheduled for release on May 1, 2004.) The orientation indicated by the external dimensions is not the correct mounting orientation. When opening mounting holes, refer to the mounting hole dimensions. Observe the precautions given in Mounting Method under *Precautions for Correct Use*.

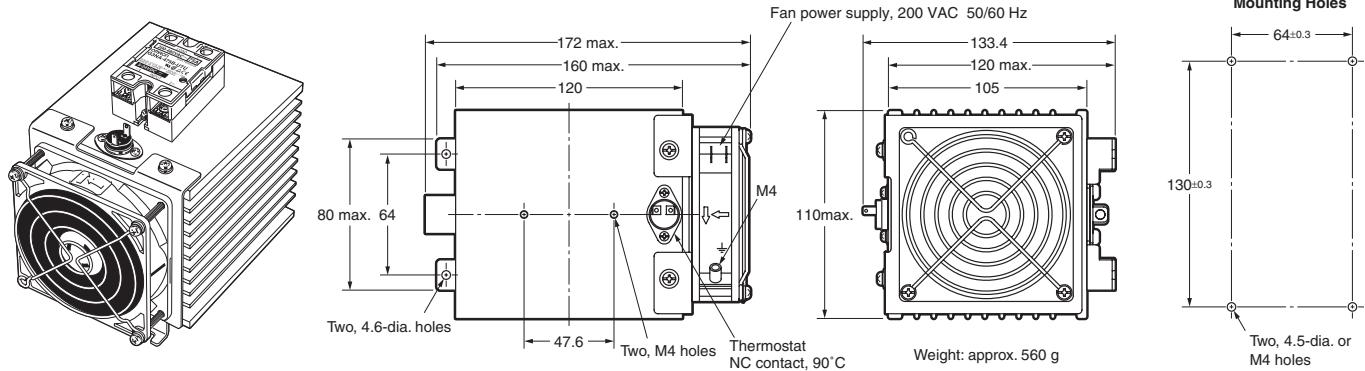

Y92B-P250

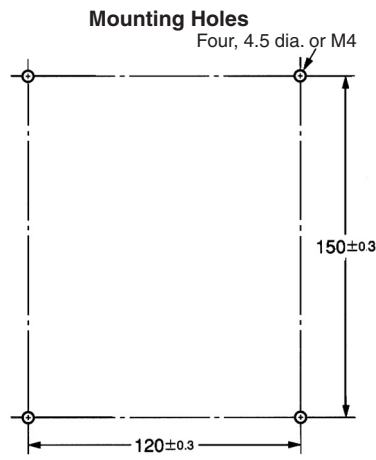
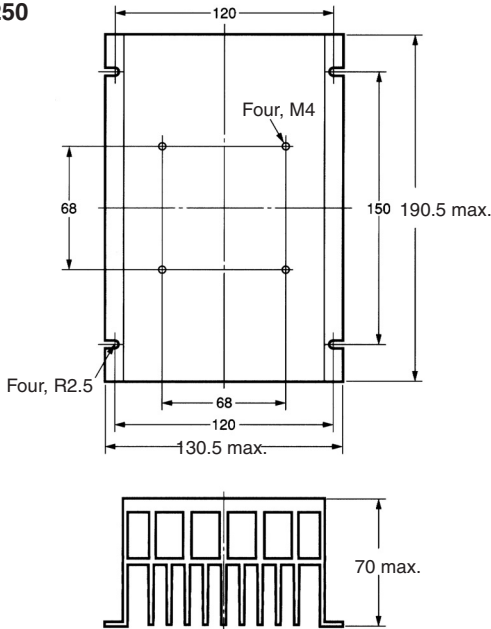

**Y92B-A100 Heat Sink
(for the G3NA-205B,
G3NA-210B, G3NA-
220B, G3NA-410B,
G3NA-420B, G3NA-
D210B)**

**Y92B-A150N Heat Sink
(for the G3NA-240B,
G3NA-440B)**

**Y92B-A250 Heat Sink
(for the G3NA-440B)**

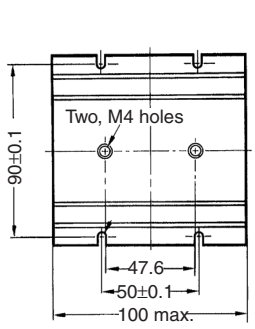

Weight: approx. 210 g

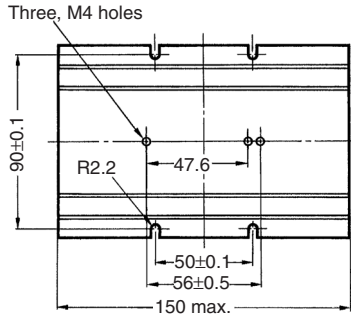

Weight: approx. 310 g

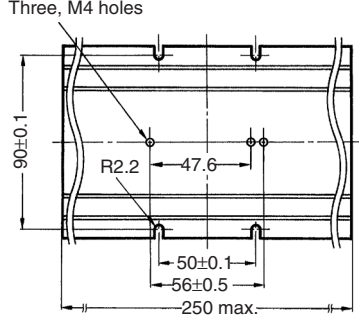

Weight: approx. 510 g

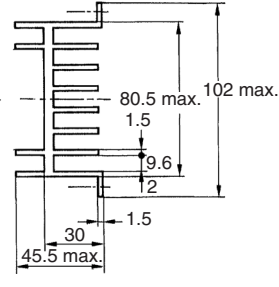

**Mounting Holes
Y92B-A100
Y92B-A150
Y92B-A250**

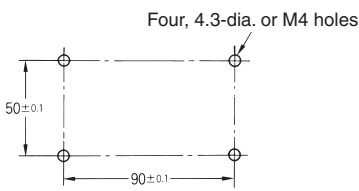

For surface mounting, a 30% derating of the load current is required (from the *Load Current vs. Ambient Temperature* graphs).
The orientation indicated by the external dimensions is not the correct mounting orientation. When opening mounting holes, refer to the mounting hole dimensions.

■ Approvals

UL (File No. E64562)/CSA (File No. LR35535)

SSR type	Input voltage	Load type	Contact ratings		
			Without heat sink	With heat sink (see note 1)	
G3NA-205B	5 to 24 VDC 100 to 120 VAC 200 to 240 VAC	General use/Tungsten	3 A, 240 VAC	5 A, 240 VAC	
		Motor	2.5 FLA, 15 LRA, 240 VAC	2.5 FLA, 15 LRA, 240 VAC	
G3NA-210B		General use/Tungsten	4 A, 240 VAC	10 A, 240 VAC	
		Motor	2.5 FLA, 15 LRA, 240 VAC	5 FLA, 30 LRA, 240 VAC	
G3NA-220B		General use/Tungsten	4 A, 240 VAC	20 A, 240 VAC	
		Motor	2.5 FLA, 15 LRA, 240 VAC	10 FLA, 60 LRA, 240 VAC	
G3NA-225B		General use/Tungsten	4 A, 240 VAC	25 A, 240 VAC	
		Motor	2.5 FLA, 15 LRA, 240 VAC	12 FLA, 72 LRA, 240 VAC	
G3NA-240B		General use/Tungsten	6 A, 240 VAC	40 A, 240 VAC	
		Motor	5 FLA, 30 LRA, 240 VAC	20 FLA, 120 LRA, 240 VAC	
G3NA-410B		5 to 24 VDC 100 to 240 VAC	General use/Tungsten	4 A, 480 VAC	10 A, 480 VAC
			Motor	2.5 FLA, 15 LRA, 480 VAC	5 FLA, 30 LRA, 480 VAC
G3NA-420B	General use/Tungsten		4 A, 480 VAC	20 A, 480 VAC	
	Motor		2.5 FLA, 15 LRA, 480 VAC	10 FLA, 60 LRA, 480 VAC	
G3NA-425B	General use/Tungsten		4 A, 480 VAC	25 A, 480 VAC	
	Motor		2.5 FLA, 15 LRA, 480 VAC	12 FLA, 72 LRA, 480 VAC	
G3NA-440B	General use/Tungsten		6 A, 480 VAC	40 A, 480 VAC	
	Motor		5 FLA, 30 LRA, 480 VAC	20 FLA, 120 LRA, 480 VAC	
G3NA-450B	General use/Tungsten		6 A, 480 VAC	50 A, 480 VAC	
	Motor		5 FLA, 30 LRA, 480 VAC	24 FLA, 144 LRA, 480 VAC	
G3NA-D210B	General use		4 A, 200 VDC	10 A, 200 VDC	

- Note:**
1. When used with the proper OMRON heat sink part number or an appropriately dimensioned equivalent.
 2. The rated values approved by each of the safety standards (e.g., UL, CSA, and TUV) may be different from the performance characteristics individually defined in this catalog.
 3. In the interest of product improvement, specifications are subject to change.

Safety Precautions

Caution
 Touching the charged section may occasionally cause minor electric shock. Do not touch the G3NA terminal section (the charged section) when the power supply is ON. Be sure to attach the cover before use.



Caution
 The G3NA and heat sink will be hot and may occasionally cause minor burns. Do not touch the G3NA or the heat sink either while the power supply is ON, or immediately after the power is turned OFF.



Caution
 The internal snubber circuit is charged and may occasionally cause minor electric shock. Do not touch the G3NA's main circuit terminals immediately after the power is turned OFF.



Caution
 Be sure to conduct wiring with the power supply turned OFF, and always attach the terminal cover after completing wiring. Touching the terminals when they are charged may occasionally result in minor electric shock.



Caution
 Do not apply a short-circuit to the load side of the G3NA. The G3NA may rupture. To protect against short-circuit accidents, install a protective device, such as a quick-burning fuse, on the power supply line.



■ Precautions for Safe Use

Although OMRON continuously strives to improve the quality and reliability of our relays, the G3NA contains semiconductors, which are generally prone to occasional malfunction and failure.

Maintaining safety is particularly difficult if a relay is used outside of its ratings. Always use the G3NA within the rated values. When using the G3NA, always design the system to ensure safety and prevent human accidents, fires, and social damage even in the event of G3NA failure, including system redundancy, measures to prevent fires from spreading, and designs to prevent malfunction.

1. G3NA malfunction or fire damage may occasionally occur. Do not apply excessive voltage or current to the G3NA terminals.
2. Heat Dissipation
 - Do not obstruct the airflow to the G3NA or heat sink. Heat generated from an G3NA error may occasionally cause the output element to short, or cause fire damage.
 - Be sure to prevent the ambient temperature from rising due to the heat radiation of the G3NA. If the G3NA is mounted inside a panel, install a fan so that the interior of the panel is fully ventilated.
 - Mount the G3NA in the specified orientation. If the G3NA is mounted in any other orientation, abnormal heat generation may cause output elements to short or may cause burning.
 - Do not use the G3NA if the heat sink fins are bent, e.g., as the result of dropping the G3NA. Heat dissipation characteristics will be reduced, possibly causing G3NA failure.
 - Apply a thin layer of Toshiba Silicone's YG6260 or Sinetsu Silicone's G746, or a similar product to the heat sink before mounting.
 - If a material with high thermal resistance, such as wood, is used, heat generated by the G3NA may occasionally cause fire or burning. When installing the G3NA directly into a control panel so that the panel can be used as a heat sink, use a panel material with low thermal resistance, such as aluminum or steel.
 - Use the specified heat sink or one with equivalent or better characteristics.

3. Wire the G3NA and tighten screws correctly, observing the following precautions
 Heat generated by a terminal error may occasionally result in fire damage. Do not operate if the screws on the output terminal are loose.
 - Abnormal heat generated by wires may occasionally result in fire damage. Use wires suitable for the load current.
 - Abnormal heat generated by terminals may occasionally result in fire damage. Do not operate if the screws on the output terminal are loose.

Tightening Torque

Screw size	Tightening torque
M4	1.2 N•m
M5	2.0 N•m

- Abnormal heat generated by terminals may occasionally result in fire damage. When tightening terminal screws, be sure that no non-conductive foreign matter is caught in screw.
 - For GN3A Relays of 40 A or higher, use crimp terminals of an appropriate size for the wire diameter for M5 terminals.
 - Do not use any wires with damaged sheaths. These may cause electric shock or leakage.
 - Do not place wiring in the same conduit or duct as high-voltage lines. Induction may cause malfunction or damage.
 - Use wires of an appropriate length, otherwise malfunction and damage may result due to induction.
 - Mount the DIN Track securely. Otherwise, the DIN Track may fall.
 - Be sure that the G3NA clicks into place when mounting it to DIN Track. The G3NA may fall if it is not mounted correctly.
 - Do not mount the G3NA when your hands are oily or dirty, e.g., with metal powder. These may cause G3NA failure.
 - Tighten the G3NA screws securely. Tightening torque: 0.78 to 0.98 N•m
 - Tighten the heat sink screws securely. Tightening torque: 0.98 to 1.47 N•m
4. Preventing Overheating
 When using the High-capacity Heat Sink (Y92B-P250NF), always use a thermostat or other method to protect from overheating in the event that the fan stops.
 5. Do Not Touch Fan Blades
 When the fan is operating, do not touch the fan blades with any part of your body or allow foreign matter to come into contact with the blades. Always attach the enclosed finger guard when using the G3NA.
 6. Operating Conditions
 - Only use the G3NA with loads that are within the rated values. Using the G3NA with loads outside the rated values may result in malfunction, damage, or burning.
 - Use a power supply within the rated frequency range. Using a power supply outside the rated frequency range may result in malfunction, damage, or burning.
 7. Do not transport the G3NA under the following conditions. Failure or malfunction may occur.
 - Conditions under which the G3NA will be exposed to water
 - High temperatures or high humidity
 - Without proper packing

Operating and Storage Locations

Do not use or store the G3NA in the following locations. Doing so may result in damage, malfunction, or deterioration of performance characteristics.

- Do not use or store in locations subject to direct sunlight.
- Do not use in locations subject to ambient temperatures outside the range -20 to 60°C.
- Do not use in locations subject to relative humidity outside the range 45% to 85% or locations subject to condensation as the result of severe changes in temperature.
- Do not store in locations subject to ambient temperatures outside the range -30 to 70°C.
- Do not use or store in locations subject to corrosive or flammable gases.
- Do not use or store in locations subject to dust (especially iron dust) or salts.
- Do not use or store in locations subject to shock or vibration.
- Do not use or store in locations subject to exposure to water, oil, or chemicals.
- Do not use or store in locations subject to high temperatures or high humidity.
- Do not use or store in locations subject to salt damage.
- Do not use or store in locations subject to rain or water drops.

Precautions for Correct Use

Please observe the following precautions to prevent failure to operate, malfunction, or undesirable effect on product performance.

Before Actual Operation

1. The G3NA in operation may cause an unexpected accident. Therefore it is necessary to test the G3NA under the variety of conditions that are possible. As for the characteristics of the G3NA, it is necessary to consider differences in characteristics between individual SSRs.
2. Unless otherwise specified, the ratings in this catalog are tested values in a temperature range between 15°C and 30°C, a relative humidity range between 25% and 85%, and an atmospheric pressure range between 88 and 106 kPa (standard test conditions according to JIS C5442). It will be necessary to provide the above conditions as well as the load conditions if the user wants to confirm the ratings of specific G3NAs.

Mounting Method

SSR Mounting Pitch (Panel Mounting)

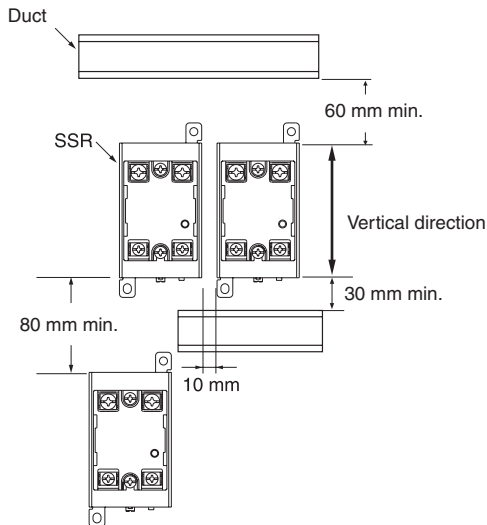

Relationship between SSRs and Duct Height

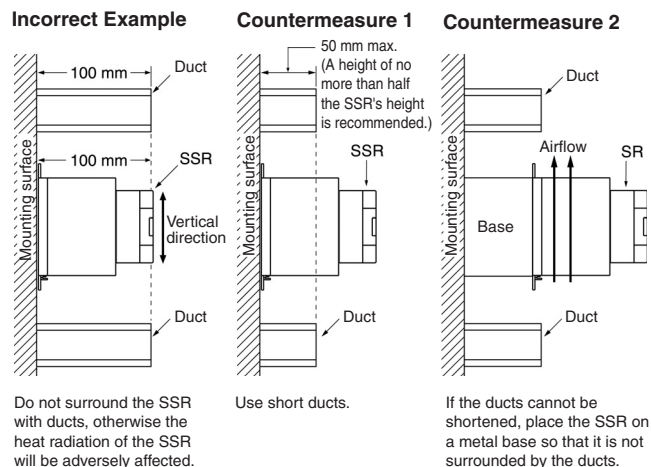

Ventilation Outside the Control Panel

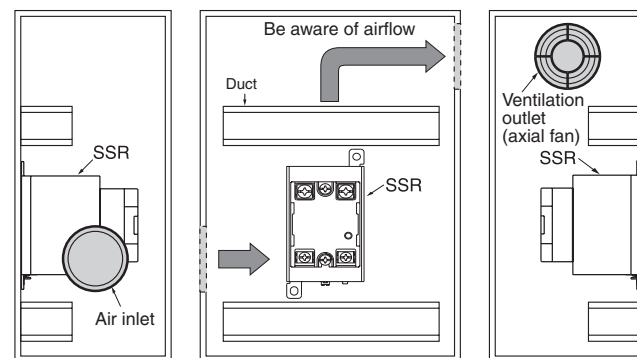

If the air inlet or air outlet has a filter, clean the filter regularly to prevent it from clogging to ensure an efficient flow of air.

Do not locate any objects around the air inlet or air outlet, otherwise the objects may obstruct the proper ventilation of the control panel.

A heat exchanger, if used, should be located in front of the SSRs to ensure the efficiency of the heat exchanger.

- Please reduce the ambient temperature of SSRs. The rated load current of an SSR is measured at an ambient temperature of 40°C.
- An SSR uses a semiconductor in the output element. This causes the temperature inside the control panel to increase due to heating resulting from the passage of electrical current through the load. To restrict heating, attach a fan to the ventilation outlet or air inlet of the control panel to ventilate the panel. This will reduce the ambient temperature of the SSRs and thus increase reliability. (Generally, each 10 °C reduction in temperature will double the expected life.)

Load current (A)	5 A	10 A	20 A	40 A	75 A	90 A
Required number of fans per SSR	0.08	0.16	0.31	0.62	1.2	1.44

Example: For 10 SSRs with load currents of 10 A,

$$0.16 \times 10 = 1.6$$

Thus, 2 fans would be required.

Size of fans: 92 mm², Air volume: 0.7 m³/min,

Ambient temperature of control panel: 30 °C

If there are other instruments that generate heat in the control panel other than SSRs, additional ventilation will be required.

High-capacity Heat Sink (Y92B-P250NF)

DIN-track Mounting

- Assembled DIN Tracks are heavy. Mount the DIN Tracks securely. Be sure that the Heat Sink is securely locked to the DIN Track.
- Attach End Plates (PFP-M, order separately) to both ends of the Units on the DIN Track to hold them in place.
- To mount a Heat Sink to a DIN Track, press down at the point indicated by arrow 1 in the diagram and then press in the Heat Sink at the point indicated by arrow 2.

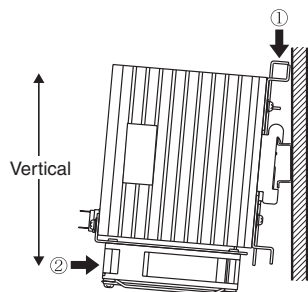

Applicable DIN Track

Mounting is possible on TE35-15Fe (IEC 60715) DIN tracks. DIN tracks from the following manufacturers can be used.

Manufacturer	Thickness: 1.5 mm	Thickness: 2.3 mm
Schneider	AM1-DE2000	---
WAGO	210-114 or 210-197	210-118
PHOENIX	N35/15	N35/15/15-2.3

Direct Mounting

- Prepare mounting holes as shown in the diagram. Tightening torque: 0.98 to 1.47 N•m

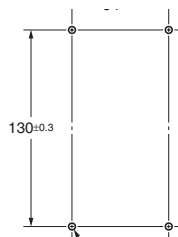

- When mounting a Heat Sink directly, first remove the Fan Unit, then mount the Heat Sink by itself before attaching the Fan Unit again. (Remove the two screws shown in the following diagram.)

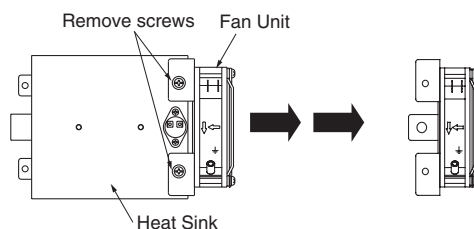

- First, temporarily mount the Heat Sink with the bottom two screws and then attach the top two screws with the mounting bracket sandwiched between the Heat Sink and mounting surface. Finally, tighten all four screws.

Ratings and Characteristics of High-capacity Heat Sink (Y92B-P250NF)

Fan Ratings

Rated voltage	200 V
Operating voltage	85% to 110% of rated voltage
Frequency	50/60 Hz
Rated current (See note.)	0.085 A at 50 Hz 0.072 A at 60 Hz
Rated speed (See note.)	2,500 r/min at 50 Hz 2,850 r/min at 60 Hz

Note: Average values.

Thermostat Ratings

Operating temperature	Approx. 90°C
Contact ratings	3 A at 240 VAC, resistive load 3 A at 24 VDC, resistive load

Fan/Thermostat Characteristics

Insulation class (Fan)	VDE: E (120°C) UL: A (105°C) CSA: B (130°C)
Protection class	1
Insulation resistance	100 MΩ min. (at 500 VDC) between power supply connections and non-charged metal part
Dielectric strength	Fan: 2,000 VAC for 1 min Thermostat: 1,500 VAC for 1 min Between power supply connections and non-charged metal part
Ambient operating temperature	-30 to 70°C (with no icing)
Storage temperature	-40 to 85°C (with no icing)
Ambient operating humidity	25% to 85%

- Use a commercial power supply (50/60 Hz) for the Fan.
- Be sure to turn OFF the power supply and wait for the blades to stop before inspecting the Fan.
- High-precision ball bearings are used in the fan and these may be damaged if the Fan is dropped or otherwise subjected to shock. The life and characteristics of the Fan will be reduced if the bearings are damaged. Do not subject the Fan to shock.
- The life of the Fan depends on the ambient temperature, As a guideline, the Fan life is 40,000 hours for continuous usage at 40°C.
- Be sure there are no objects near the air vents that would restrict air flow and no loose objects, such as electrical lines.
- The tightening torque of the mounting screw when replacing the Fan is 0.38 to 0.50 N•m.
- Terminals equivalent to Faston #110 are used for the Fan power supply terminals.
- Connect the ground screw hole on the fan to PE.

Preventing Overheating with a High-capacity Heat Sink (Y92B-P250NF)

- When the High-capacity Heat Sink is used, high-capacity switching at 75 A or 90 A requires forced cooling with a fan. Connect the Fan to a power supply according to its ratings specifications.
- If the Fan stops due to a power supply error, due to foreign matter in the power supply connection, or due to aging, the Heat Sink will heat to high temperatures, possibly resulting in failure of the SSR or adverse affects on other devices. Implement an overheating prevention measure, such as turning OFF the load current, if the Heat Sink overheats.
- A thermostat is provided to detect overheating. The thermostat uses a NC contact, i.e., the circuit will be opened for overheating. This thermostat can be used to stop the operation of the SSR. Implement an overheating prevention measure by using this signal to output an alarm or perform another response applicable to the system. Also, confirm that there is no problem with the overall system.
- Do not connect the thermostat directly to the load power supply. Connect it to a contactor or other shutoff device connected above the SSR.
- Terminals equivalent to Faston #187 are used for the thermostat terminals.
- Do not place heat-dissipating silicon grease on the thermostat.
- Do not solder the thermostat terminals.
- The following diagram shows a protective circuit example.

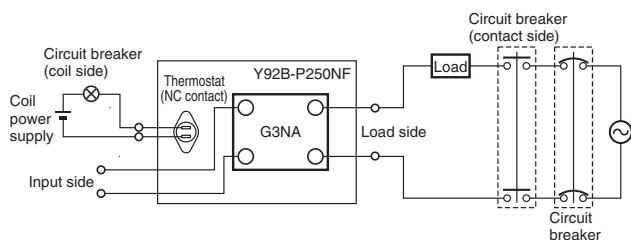

Ventilating a High-capacity Heat Sink (Y92B-P250NF)

- Refer to *Ventilation Outside the Control Panel*.

Operating Conditions

- Do not apply currents exceeding the rated current otherwise, the temperature of the G3NA may rise excessively.
- As protection against accidents due to short-circuiting, be sure to install protective devices, such as fuses and no-fuse breakers, on the power supply side.
- Do not apply overvoltages to the input circuit or output circuit. Failure or burning may result.
- Do not drop the G3NA or otherwise subject it to abnormal shock. Malfunction or failure may result.
- Keep the cooling system running continuously during the ON/OFF operation of the SSR. This is to allow residual heat to dissipate while the SSR is OFF.

Noise Terminal Voltage According to EN55011

The G3NA-UTU complies with EN55011 standards when a capacitor is connected to the load power supply as shown in the following circuit diagram.

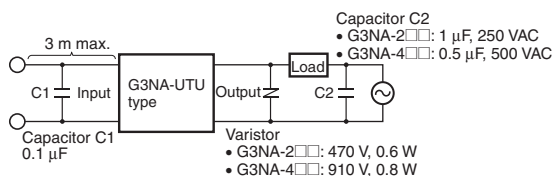

- Connect capacitor C1 to both sides of the input terminals for a G3NA with a DC input.
- Connect capacitor C2 to both sides of the load power supply output.
- Connect the varistor to both sides of the G3NA output terminals.
- Do not use an input line that is longer than 3 m.

Loss Time

The loss time will increase when the G3NA is used at a low applied voltage or current. Be sure that this does not cause any problems.

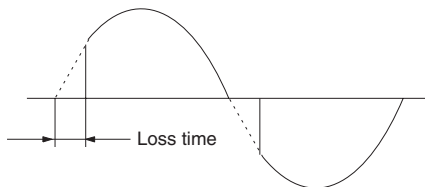

Using DC Loads

For a DC or L load, a diode should be connected in parallel the load to absorb the counter electromotive force of the load.

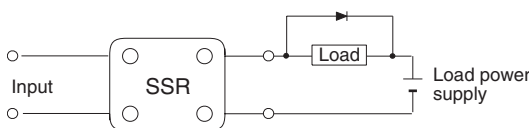

Fuses

Connect a quick-break fuse in series with the load as a short-circuit protection measure. Use one of the fuses in the following table or one with equivalent or better characteristics.

Recommended Fuses

G3NA rated load current	Fuse model	Manufacturer	Applicable SSR
5 A	60LFF5	Kyosan Electric Manufacturing Company	G3NA-205B
8 A	60LFF8		G3NA-210B
10 A	60LFF10		G3NA-220B
15 A	60LFF15		G3NA-240B
20 A	60LFF20 50SHA20		G3NA-275B-UTU
25 A	60PFF25 50SHA25		G3NA-290B-UTU
30 A	60PFF30 50SHA30		
40 A	50SHA40		
45 A	50SHA45		
50 A	50SHA50		
75 A	50SHA75		
80 A	50SHA80		
100 A	50SHB100		

Reverse Connection

The output terminal side of the G3NA-D210B is connected to a built-in diode to protect the SSR from damage that may result from reverse connection. The SSR, however, cannot withstand one minute or more if the wires are connected in reverse. Therefore, pay the utmost attention not to make polarity mistakes on the load side.

■ Precautions on Operating and Storage Environments

1. Operating Ambient Temperature

The rated value for the ambient operating temperature of the G3NA is for when there is no heat build-up. For this reason, under conditions where heat dissipation is not good due to poor ventilation, and where heat may build up easily, the actual temperature of the G3NA may exceed the rated value resulting in malfunction or burning.

When using the G3NA, design the system to allow heat dissipation sufficient to stay below the *Load Current vs. Ambient Temperature* characteristic curve. Note also that the ambient temperature of the G3NA may increase as a result of environmental conditions (e.g., climate or air-conditioning) and operating conditions (e.g., mounting in an airtight panel).

2. Transportation

When transporting the G3NA, observe the following points. Not doing so may result in damage, malfunction, or deterioration of performance characteristics.

- Do not drop the G3NA or subject it to severe vibration or shock.
- Do not transport the G3NA if it is wet.
- Do not transport the G3NA under high temperatures or humidity.
- Do not transport the G3NA without packing it properly.

3. Vibration and Shock

Do not subject the G3NA to excessive vibration or shock. Otherwise the G3NA may malfunction and internal components may be deformed or damaged, resulting in failure of the G3NA to operate. To prevent the G3NA from abnormal vibration, do not install the G3NA in locations or by means that will subject it to vibration from other devices, such as motors.

4. Solvents

Do not allow the G3NA or the resin portion of the Fan's thermostat to come in contact with solvents, such as thinners or gasoline. Doing so will dissolve the markings on the G3NA.

5. Oil

Do not allow the G3NA terminal cover to come in contact with oil. Doing so will cause the cover to crack and become cloudy.

■ Operation

1. Leakage Current

A leakage current flows through a snubber circuit in the G3NA even when there is no power input. Therefore, always turn OFF the power to the input or load and check that it is safe before replacing or wiring the G3NA.

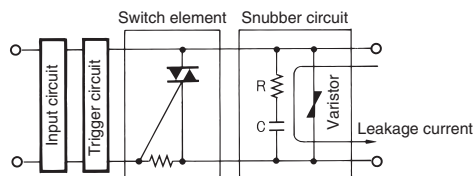

2. Screw Tightening Torque

Tighten the G3NA terminal screws properly. If the screws are not tight, the G3NA will be damaged by heat generated when the power is ON. Perform wiring using the specified tightening torque.

3. Handling Relays

Do not mount the G3NA when your hands are oily or dirty, e.g., with metal powder. These may cause G3NA failure.

4. Do Not Drop

Be careful not to drop a Relay or Heat Sink onto any part of your body while working. Injury may result. This is particularly true for the High-capacity Heat Sink (Y92B-P250NF), which weighs 2.5 kg.

Terms and Conditions of Sale

1. **Offer; Acceptance.** These terms and conditions (these "Terms") are deemed part of all quotations, acknowledgments, invoices, purchase orders and other documents, whether electronic or in writing, relating to the sale of products or services (collectively, the "Products") by Omron Electronic Components LLC ("Seller"). Seller hereby objects to any terms or conditions proposed in Buyer's purchase order or other documents which are inconsistent with, or in addition to, these Terms.
2. **Prices; Payment.** All prices stated are current, subject to change without notice by Seller. Buyer agrees to pay the price in effect at time of shipment. Payments for Products received are due net 30 days unless otherwise stated in the invoice.
3. **Discounts.** Cash discounts, if any, will apply only on the net amount of invoices sent to Buyer after deducting transportation charges, taxes and duties, and will be allowed only if (i) the invoice is paid according to Seller's payment terms and (ii) Buyer has no past due amounts owing to Seller.
4. **Currencies.** If the prices quoted herein are in a currency other than U.S. dollars, Buyer shall make remittance to Seller at the then current exchange rate most favorable to Seller and which is available on the due date; provided that if remittance is not made when due, Buyer will convert the amount to U.S. dollars at the then current exchange rate most favorable to Seller available during the period between the due date and the date remittance is actually made.
5. **Governmental Approvals.** Buyer shall be responsible for, and shall bear all costs involved in, obtaining any government approvals required for the importation or sale of the Products.
6. **Taxes.** All taxes, duties and other governmental charges (other than general real property and income taxes), including any interest or penalties thereon, imposed directly or indirectly on Seller or required to be collected directly or indirectly by Seller for the manufacture, production, sale, delivery, importation, consumption or use of the Products sold hereunder (including customs duties and sales, excise, use, turnover and license taxes) shall be charged to and remitted by Buyer to Seller.
7. **Financial.** If the financial position of Buyer at any time becomes unsatisfactory to Seller, Seller reserves the right to stop shipments or require satisfactory security or payment in advance. If Buyer fails to make payment or otherwise comply with these Terms or any related agreement, Seller may (without liability and in addition to other remedies) cancel any unshipped portion of Products sold hereunder and stop any Products in transit until Buyer pays all amounts, including amounts payable hereunder, whether or not then due, which are owing to it by Buyer. Buyer shall in any event remain liable for all unpaid accounts.
8. **Cancellation; Etc.** Orders are not subject to rescheduling or cancellation unless Buyer indemnifies Seller fully against all costs or expenses arising in connection therewith.
9. **Force Majeure.** Seller shall not be liable for any delay or failure in delivery resulting from causes beyond its control, including earthquakes, fires, floods, strikes or other labor disputes, shortage of labor or materials, accidents to machinery, acts of sabotage, riots, delay in or lack of transportation or the requirements of any government authority.
10. **Shipping; Delivery.** Unless otherwise expressly agreed in writing by Seller:
 1. Shipments shall be by a carrier selected by Seller;
 2. Such carrier shall act as the agent of Buyer and delivery to such carrier shall constitute delivery to Buyer;
 3. All sales and shipments of Products shall be FOB shipping point (unless otherwise stated in writing by Seller), at which point title to and all risk of loss of the Products shall pass from Seller to Buyer, provided that Seller shall retain a security interest in the Products until the full purchase price is paid by Buyer;
 4. Delivery and shipping dates are estimates only.
 5. Seller will package Products as it deems proper for protection against normal handling and extra charges apply to special conditions.
11. **Claims.** Any claim by Buyer against Seller for shortage or damage to the Products occurring before delivery to the carrier must be presented in writing to Seller within 30 days of receipt of shipment and include the original transportation bill signed by the carrier noting that the carrier received the Products from Seller in the condition claimed.
12. **Warranties.** (a) **Exclusive Warranty.** Seller's exclusive warranty is that the Products will be free from defects in materials and workmanship for a period of twelve months from the date of sale by Seller (or such other period expressed in writing by Seller). Seller disclaims all other warranties, express or implied. (b) **Limitations.** SELLER MAKES NO WARRANTY OR REPRESENTATION, EXPRESS OR IMPLIED, ABOUT NON-INFRINGEMENT, MERCHANTABILITY OR FITNESS FOR A PARTICULAR PURPOSE OF THE PRODUCTS. BUYER ACKNOWLEDGES THAT IT ALONE HAS DETERMINED THAT THE PRODUCTS WILL SUITABLY MEET THE REQUIREMENTS OF THEIR INTENDED USE. Seller further disclaims all warranties and responsibility of any type for claims or expenses based on infringement by the Products or otherwise of any intellectual property right. (c) **Buyer Remedy.** Seller's sole obligation hereunder shall be to replace (in the form originally shipped with Buyer responsible for labor charges for removal or replacement thereof) the non-complying Product or, at Seller's election, to repay or credit Buyer an amount equal to the purchase price of the Product; provided that in no event shall Seller be responsible for warranty, repair, indemnity or any other claims or expenses regarding the Products unless Seller's analysis confirms that the Products were properly handled, stored, installed and maintained and not subject to contamination, abuse, misuse or inappropriate modification. Return of any Products by Buyer must be approved in writing by Seller before shipment. Seller shall not be liable for the suitability or unsuitability or the results from the use of Products in combination with any electrical or electronic components, circuits, system assemblies, or any other materials or substances or environments. Any advice, recommendations or information given orally or in writing are not to be construed as an amendment to the above warranty.
13. **Limitation on Liability; Etc.** SELLER SHALL NOT BE LIABLE FOR SPECIAL, INDIRECT, INCIDENTAL OR CONSEQUENTIAL DAMAGES, LOSS OF PROFITS OR PRODUCTION OR COMMERCIAL LOSS IN ANY WAY CONNECTED WITH THE PRODUCTS, WHETHER SUCH CLAIM IS BASED IN CONTRACT, WARRANTY, NEGLIGENCE OR STRICT LIABILITY. Further, in no event shall liability of Seller exceed the individual price of the Product on which liability is asserted.
14. **Indemnities.** Buyer shall indemnify and hold harmless Seller, its affiliates and its employees from and against all liabilities, losses, claims, costs and expenses (including attorney's fees and expenses) related to any claim, investigation, litigation or proceeding (whether or not Seller is a party) which arises or is alleged to arise from Buyer's acts or omissions under these Terms or in any way with respect to the Products. Without limiting the foregoing, Buyer (at its own expense) shall indemnify and hold harmless Seller and defend or settle any action brought against Seller to the extent that it is based on a claim that any Product made to Buyer specifications infringed intellectual property rights of another party.
15. **Property; Confidentiality.** The intellectual property embodied in the Products is the exclusive property of Seller and its affiliates and Buyer shall not attempt to duplicate it in any way without the written permission of Seller. Notwithstanding any charges to Buyer for engineering or tooling, all engineering and tooling supplied by Seller to Buyer relating to the Products are confidential and proprietary, and Buyer shall limit distribution thereof to its trusted employees and strictly prevent disclosure to any third party.
16. **Miscellaneous.** (a) **Waiver.** No failure or delay by Seller in exercising any right and no course of dealing between Buyer and Seller shall operate as a waiver of rights by Seller. (b) **Assignment.** Buyer may not assign its rights hereunder without Seller's written consent. (c) **Law.** These Terms are governed by Illinois law (without regard to conflict of law principles). Federal and state courts in Illinois shall have exclusive jurisdiction for any dispute hereunder. (d) **Amendment.** These Terms constitute the entire agreement between Buyer and Seller relating to the Products, and no provision may be changed or waived unless in writing signed by the parties. (e) **Severability.** If any provision hereof is rendered ineffective or invalid, such provision shall not invalidate any other provision. (f) **Setoff.** Buyer shall have no right to set off any amounts against the amount owing in respect of this invoice. (g) **Definitions.** As used herein, "including" means "including without limitation".

Certain Precautions on Specifications and Use

1. **Suitability for Use.** Seller shall not be responsible for conformity with any standards, codes or regulations which apply to the combination of the Product in Buyer's application or use of the Product. At Buyer's request, Seller will provide applicable third party certification documents identifying ratings and limitations of use which apply to the Product. This information by itself is not sufficient for a complete determination of the suitability of the Product in combination with the end product, machine, system, or other application or use. Buyer shall be solely responsible for determining appropriateness of the particular Product with respect to Buyer's application, product or system. Buyer shall take application responsibility in all cases but the following is a non-exhaustive list of applications for which particular attention must be given:
 - (i) Outdoor use, uses involving potential chemical contamination or electrical interference, or conditions or uses not described in this document.
 - (ii) Energy control systems, combustion systems, railroad systems, aviation systems, medical equipment, amusement machines, vehicles, safety equipment, and installations subject to separate industry or government regulations.
 - (iii) Use in consumer products or any use in significant quantities.
 - (iv) Systems, machines and equipment that could present a risk to life or property. Please know and observe all prohibitions of use applicable to this product.

NEVER USE THE PRODUCT FOR AN APPLICATION INVOLVING SERIOUS RISK TO LIFE OR PROPERTY WITHOUT ENSURING THAT THE SYSTEM AS A WHOLE HAS BEEN DESIGNED TO ADDRESS THE RISKS, AND THAT THE OMRON PRODUCT IS PROPERLY RATED AND INSTALLED FOR THE INTENDED USE WITHIN THE OVERALL EQUIPMENT OR SYSTEM.
2. **Programmable Products.** Seller shall not be responsible for the user's programming of a programmable product, or any consequence thereof.
3. **Performance Data.** Performance data given in this publication is provided as a guide for the user in determining suitability and does not constitute a warranty. It may represent the result of Seller's test conditions, and the users must correlate it to actual application requirements. Actual performance is subject to Seller's Warranty and Limitations of Liability.
4. **Change in Specifications.** Product specifications and accessories may be changed at any time based on improvements and other reasons. It is our practice to change part numbers when published ratings or features are changed or when significant construction changes are made. However, some specifications of the Product may be changed without any notice. When in doubt, special part numbers may be assigned to fix or establish key specifications for your application. Please consult with your Seller representative at any time to confirm actual specifications of purchased Product.
5. **Errors and Omissions.** The information in this publication has been carefully checked and is believed to be accurate; however, no responsibility is assumed for clerical, typographical or proofreading errors, or omissions.
6. **RoHS Compliance.** Where indicated, our products currently comply, to the best of our knowledge as of the date of this publication, with the requirements of the European Union's Directive on the Restriction of certain Hazardous Substances ("RoHS"), although the requirements of RoHS do not take effect until July 2006. These requirements may be subject to change. Please consult our website for current information.

Complete "Terms and Conditions of Sale" for product purchase and use are on Omron's website at www.components.omron.com – under the "About Us" tab, in the Legal Matters section.

ALL DIMENSIONS SHOWN ARE IN MILLIMETERS.

To convert millimeters into inches, multiply by 0.03937. To convert grams into ounces, multiply by 0.03527.

OMRON®

**OMRON ELECTRONIC
COMPONENTS LLC**

55 E. Commerce Drive, Suite B
Schaumburg, IL 60173

847-882-2288

OMRON CANADA, INC.

885 Milner Avenue
Toronto, Ontario M1B 5V8

416-286-6465

OMRON ON-LINE

Global - <http://www.omron.com>

USA - <http://www.components.omron.com>

Canada - <http://www.omron.ca>